

PART NO. 2501XXHA001
 DWG NO. C2501HA

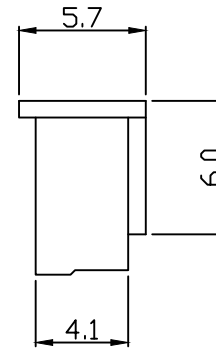
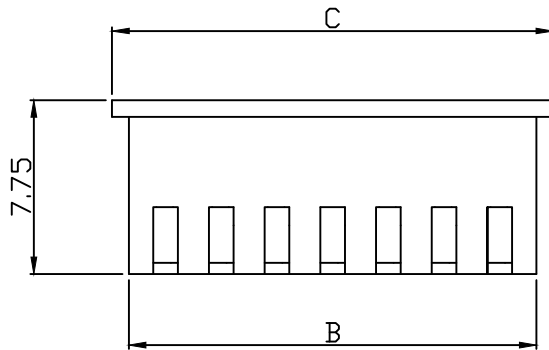
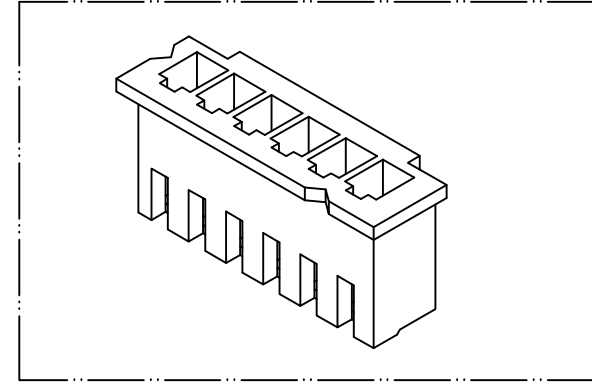
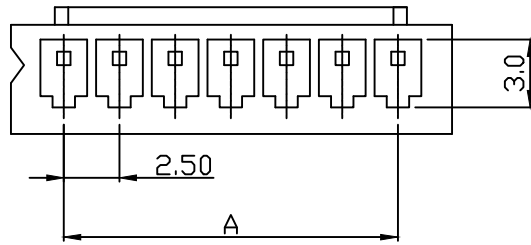

Dimensional & Ordering Information:

Part No.	Circuits	Dim A	Dim B	Dim C
250102HA001	2	2.5	5.7	7.3
250103HA001	3	5.0	8.2	9.8
250104HA001	4	7.5	10.7	12.3
250105HA001	5	10.0	13.2	14.8
250106HA001	6	12.5	15.7	17.3
250107HA001	7	15.0	18.2	19.8
250108HA001	8	17.5	20.7	22.3
250109HA001	9	20.0	23.2	24.8
250110HA001	10	22.5	25.7	27.3
250111HA001	11	25.0	28.2	29.8
250112HA001	12	27.5	30.7	32.3
250113HA001	13	30.0	33.2	34.8
250114HA001	14	32.5	35.7	37.3
250115HA001	15	35.0	38.2	39.8
250116HA001	16	37.5	40.7	42.3
250117HA001	17	40.0	43.2	44.8
250118HA001	18	42.5	45.7	47.3
250119HA001	19	45.0	48.2	49.8
250120HA001	20	47.5	50.7	52.3

NOTE:

1. Housing Material: Nylon 66 UL 94V-0
2. Insulation resistance: 1000M Ω /min.
3. Withstand voltage: 1000V AC/minute.
4. Current rating: 3A AC/DC.
5. Voltage rating: 250V AC/DC

UNLESS OTHERWISE SPECIFIED TOLERANCES
 3 PLACE $\pm 0.5 \pm 0.10$
 2 PLACE $\pm 1.5 \pm 0.25$
 1 PLACE $\pm 2.0 \pm 0.50$
 ANGLE DIM



REV.	REVISION	DIS	DATE
SCALE	REV.	PAGE	UNIT
5/1	A	1	mm

DWG NO: C2501HA

PART NO: 2501xxHA001

