

THIS DRAWING IS UNPUBLISHED. RELEASED FOR PUBLICATION 2012
 © COPYRIGHT copyright dbTeTE CONNECTIVITY ALL RIGHTS RESERVED.

REVISIONS				
P	LTR	DESCRIPTION	DATE	APVD
E3		REV PER ECN-21-124923	08NOV2021	DS DS
-	-	-	-	-
-	-	-	-	-
-	-	-	-	-

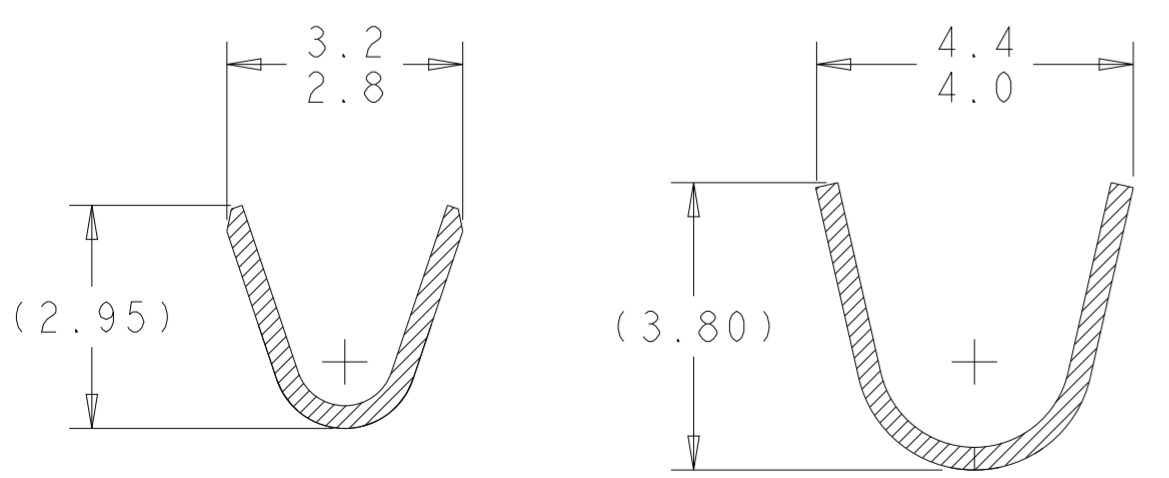
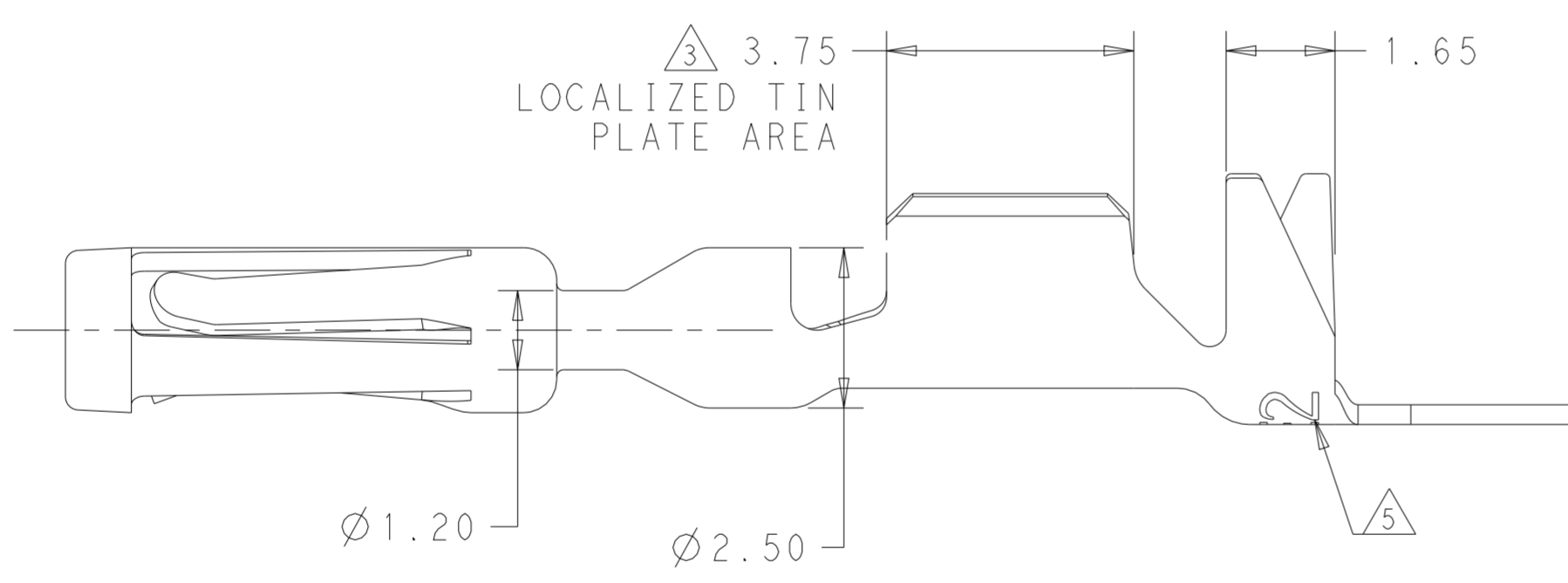
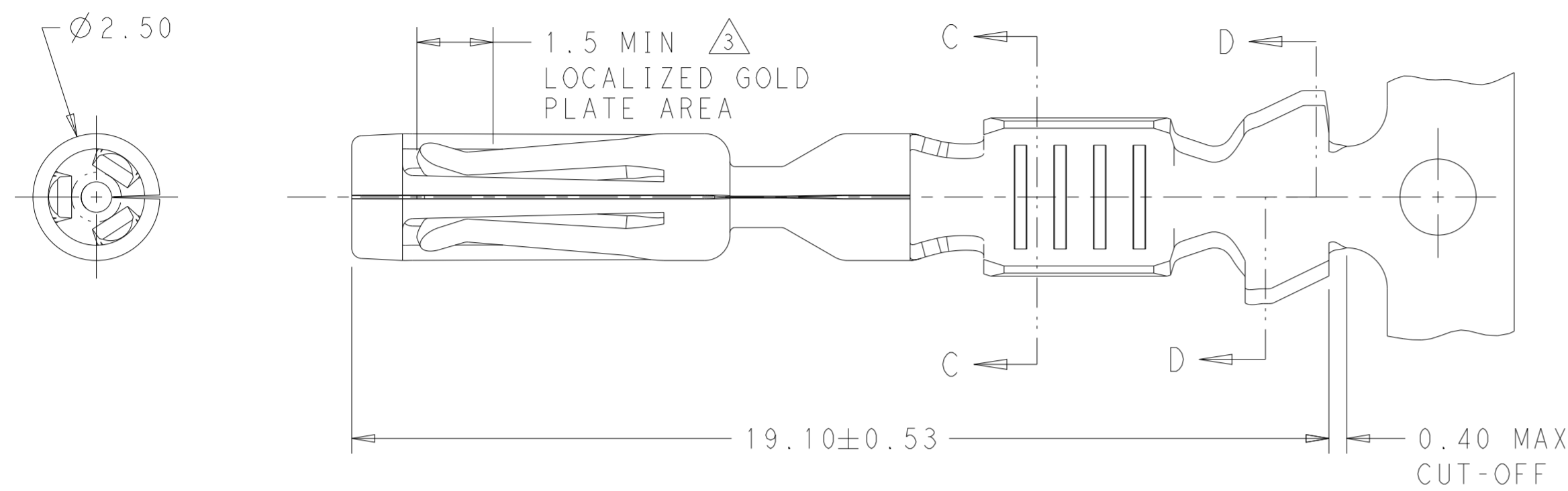

SECTION C-C ROTATED 90° CW
 SECTION D-D ROTATED 90° CW
 16-20 AWG WIRE

- THE WIRE SIZES QUALIFIED FOR THIS TERMINAL ARE LISTED BELOW SHOWING THE AWG SIZE AND THE METRIC EQUIVALENT
 20AWG - 0.5mm²
 18AWG - 0.8mm²
 16AWG - 1.0mm²

 THE TERMINAL HAS ALSO BEEN QUALIFIED TO THE SPECIFIC METRIC WIRE SIZES LISTED BELOW
 1.0mm²FLRY
 1.5mm²FLRY
- INSULATION RANGE: 1.10-2.70.
- △ .00075 MIN GOLD IN THE LOCALIZED GOLD PLATE AREA, .0025 MIN MATTE TIN IN THE LOCALIZED TIN PLATE AREA OVER .00125 MIN NICKEL OVER ENTIRE CONTACT
- USED WITH AMPSEAL PLUG ASSEMBLY: 776286, 776273, 770680, 776164
- △ DIE IDENTIFIER, T275 AND TE2, LOCATED IN THIS AREA.

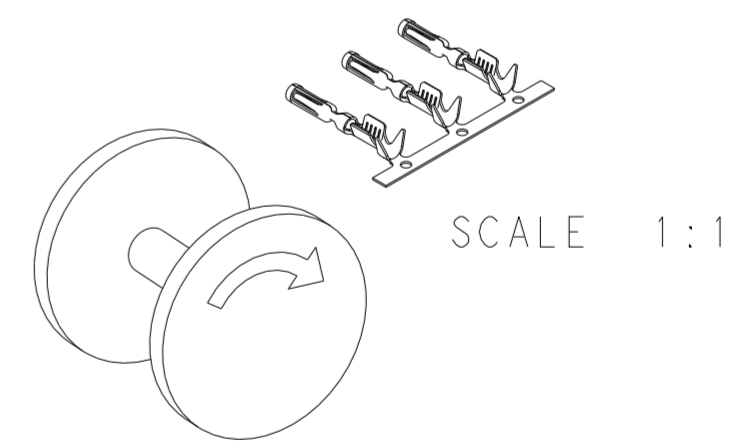

FIGURE 1
 FINAL PAYOUT DIRECTION

770854-3	16-20	GOLD △	0.30 COPPER ALLOY	770520-3
770854-1	16-20	TIN	0.30 COPPER ALLOY	770520-1
LOOSE PIECE	WIRE GAGE AWG	FINISH	MATERIAL	PART NUMBER

THIS DRAWING IS A CONTROLLED DOCUMENT.		DWN R. VESTAL 19 JUN 2012	TE Connectivity	
DIMENSIONS: mm		CHK D. STRAUSSER 19 JUN 2012		
TOLERANCES UNLESS OTHERWISE SPECIFIED:		APVD D. STRAUSSER 19 JUN 2012	NAME CONTACT, AMPSEAL	
0 PLC ±		PRODUCT SPEC	108-1329	
1 PLC ±		APPLICATION SPEC	114-16016	
2 PLC ±		WEIGHT	-	
3 PLC ±		SIZE	A200779	
4 PLC ±		CAGE CODE	C-770520	
ANGLES ±		DRAWING NO	RESTRICTED TO	
FINISH		SCALE	10:1	
MATERIAL SEE TABLE		CUSTOMER DRAWING	SHEET 1 OF 1	
SEE TABLE		REV	E3	