

User operation manual

Electric heating air heating machine

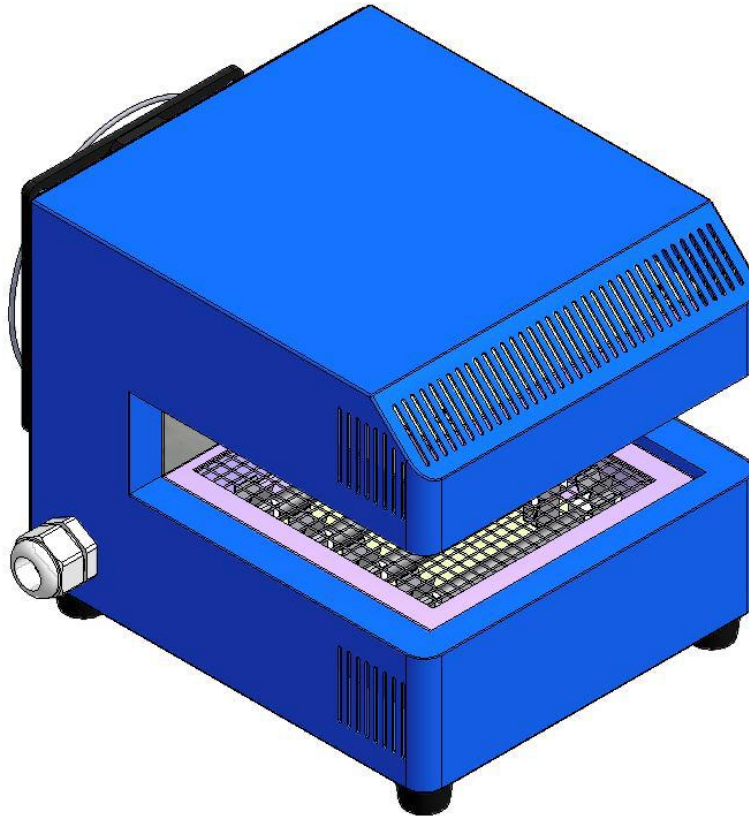

I、 Safety Guide.....	4
II、 Product overview.....	4
1、 Summary.....	4
2、 Equipment parameters.....	4
3、 Equipment Composition.....	5
4、 Equipment characteristics.....	5
5、 Main technical parameters.....	5
III 、 Install.....	5
1、 Equipment Dimensions.....	5
2、 Equipment installation.....	6
3、 Power Supply Specification and Connecting Wire.....	7
IV、 Equipment debugging.....	7
1、 Controller Panel Diagram.....	7
2、 Controller parameter setting.....	8
2.1 Start-up.....	8
2.2 Interface Description.....	8
2.3 Key Setting Instructions.....	8
2.4 Function List.....	9
3、 Controller parameter setting.....	10
3.1 side install.....	10
3.2 Front Installation.....	11
V 、 equipment running.....	11
1、 Operation mode.....	11
1.1Single operation mode.....	11
1.2Circulating operation mode.....	11
2、 Single run mode operation.....	11
3、 Circulating operation mode.....	12
VI、 Common failures and Solutions.....	12
VII、 Replacement Method of Heating Pipe.....	13
VIII、 Contact me.....	13
Packing list.....	14
Certificate.....	15

I、 Safety Guide

Warning! Only professional technicians are allowed to install and debug the equipment!

Warning! Even if the equipment stops running, the temperature in the heating zone may still be very high!

Warning! When the equipment is working properly, there will be high temperature on the surface of the box body. Please do not contact directly with the skin to avoid scalding.

Warning! The PE line of this equipment must be connected with the PE line in the factory.

II、 Product overview

1、 Summary

WLRS1010-Zheat-shrinkable tube heater can adopt various control modes, and can adjust heating time and stopping time freely according to actual needs. It can start heating by manual triggering or start-stop mode of automatic circulation heating.

The split design enables the machine heating system to be used separately, or can be deployed on large-scale heating equipment as required, but the heating power is less than or equal to the rated output power of the controller.

This machine is suitable for heating shrinkage of heat shrinkable pipe in wire harness processing enterprises. It can adjust operation time, working time and heating zone width arbitrarily according to production process requirements. It can work continuously for 24 hours without interruption.

2、 Equipment parameters

Classification	Item	Parameter
Size	Overall machine size(L×W×H)	190×258×180mm
	Control Power Supply (L×W×H)	194×194×140mm
	Heating area (L×W×H)	170×150×40mm
	Wire Harness Heating Length	<120mm
	Wire Harness Heating Diameter	<40mm
Heating pipe	Heating pipe name	Infrared heating tube
	Heating pipe power(max)	300W×6(standard configuration)
Power source	Power Specification	AC--220V 50Hz/60Hz
	power supply	1900W(standard)

		configuration)
Safety	Safety protection	PE

3、 Equipment Composition

The equipment consists of two parts, which can be disassembled or assembled into a whole.

A. Heating system: consisting of electrical components of heat source and mechanical components of fixed heat source.

B. Control system: control equipment operation mode, and adjust heating time and operation interval.

4、 Equipment characteristics

Various working modes can be adjusted at will, and the power of heating zone can be adjusted according to the actual situation, and 1-8 infrared radiation tubes can be selected for heating.

5、 Main technical parameters

A、 AC power source: AC-220V $\pm 10\%$

B、 Maximum output power: 1900W

C、 Measure input impedance: $> 4 \text{ M}\Omega$

D、 Relative humidity: $\leq 85 \%$

III 、 Install

1、 Equipment Dimensions

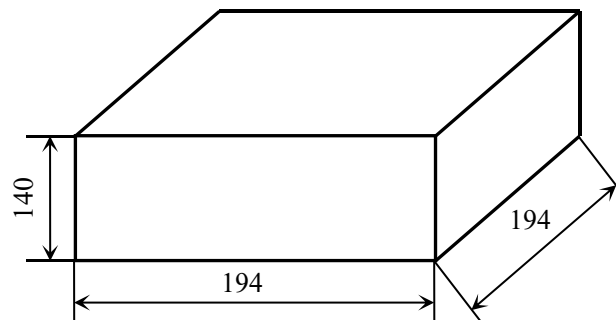

Control box size

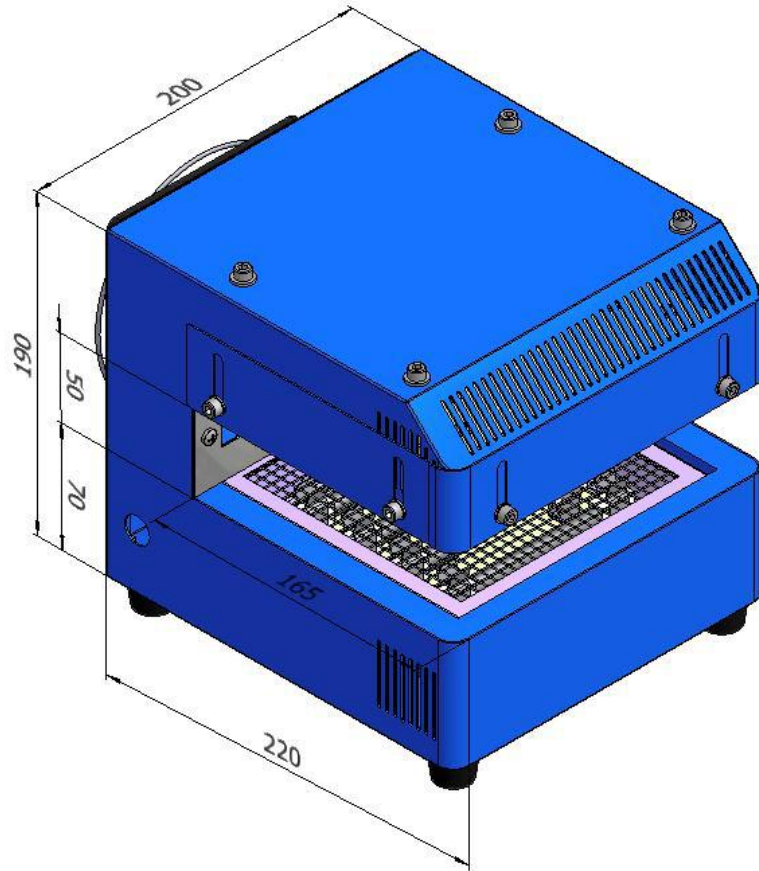

Heating box size

2、 Equipment installation

The equipment adopts split design, with high automation and no need for customer assembly. Please put the equipment on a safe and stable platform, and it will run when it is turned on. The back of the machine should not be too close to the wall to facilitate the heat dissipation of the machine.

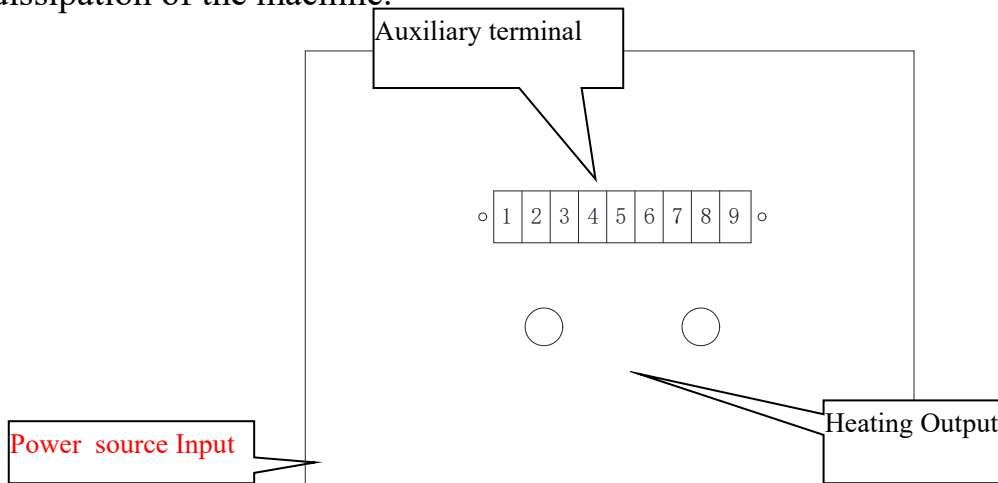

Schematic diagram of connection hole position at back of control box

Power source Input: External Power Access Line

Heating Output: Heater Connection Line in Heating System - L11/N11

Auxiliary terminal wiring definition:

1#: Photoelectric Sensor +V (Brown) ---P24V

2#: Photoelectric Sensor 0V (Black) ---P0V

3#: Photoelectric Sensor Output (Blue) -- OUT

4 #: Empty

5 #: Empty

6 #: Empty

7 #: Fan - L22

8 #: Fan - N22

9 #: Earthing terminal (PE)

3、 Power Supply Specification and Connecting Wire

The specification of power supply is AC220V+PE wire. Output power 1.9KW.

Circuit	Corresponding machine wire number
Single-phase	L
Neutral	N
	PE

IV、 Equipment debugging

1、 Controller Panel Diagram

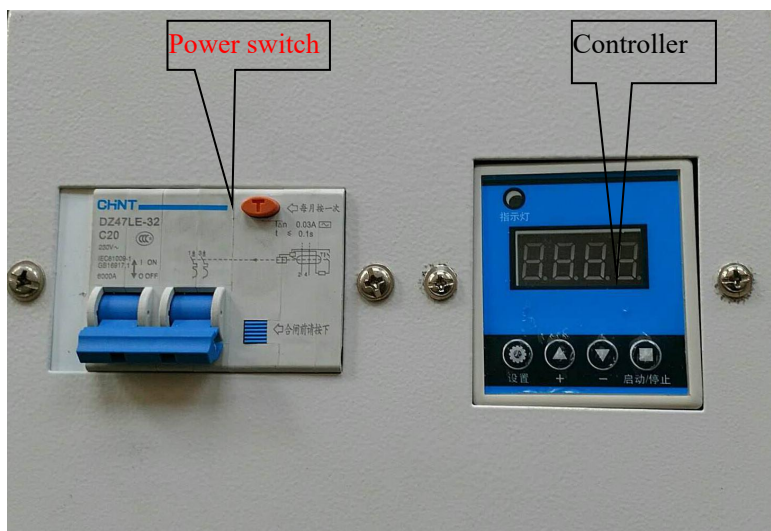

A. Power switch: After the left circuit breaker of the heating control system closes upward, the system supplies power.

B. Controller: Select operation mode and heating and stopping time.

2、Controller parameter setting

2.1 Start-up

When in use, the power interface of the controller is connected to the adapted working power according to the local power, and the power PE wire is connected well. Close the 2P circuit breaker on the left side of the operating box, and the power indicator lights up. The controller is shown in the following figure.

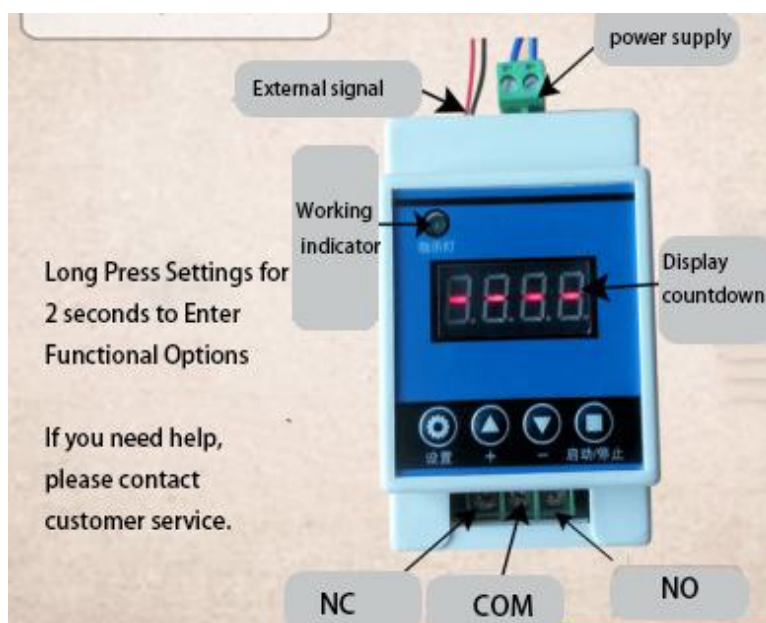

picture1

2.2 Interface Description

- A、 L (Power Supply): Single-phase Line of Input AC Power Supply
- B、 N (Power Supply): Neutral Line of Input AC Power Supply
- C、 NO (Normally Opened): Relays often open interfaces. Relays are suspended before suction and are short-connected with COM after suction.
- D、 COM (Public): Relay Public Interface
- E、 NC (Normally Closed): Normally Closed Interface of Relay, Short Connection with COM before Relay Suction, Suspension after Suction

2.3 Key Setting Instructions

When the power is switched on, the display of "----" indicates that it is in standby state.

Press "Settings" for the first time (it takes more than 1 second to be effective to prevent false triggering), and display: P-11:"+"-"-"Start/Stop" adjustment function mode. For example, you need to run P-13 mode, press the "+"-"-" button, and adjust the display to P-13.

Press "Settings" for the second time, and the screen shows:
A001:"+"-"-"Start/Stop"to adjust the first time A.

Press "Settings" for the third time, and the screen shows:
B001:"+"-"-"Start/Stop"to adjust the second time B

Press "Settings" for the fourth time, Displaying "----" indicates entering standby state

Start/Stop as Start/Stop Signal for All Functions in Standby State

2.4. Function List

- P-11: Follow mode (If the signal is ON, relay suction, otherwise, not suction)
- P-12: Self-locking (Provides a signal relay to suck in and a signal relay to stop)
- P-13: Give the signal, the relay will stop automatically after pulling in A seconds; Invalid trigger during delay.
- P-14: Give the signal, the relay will stop automatically after pulling in A seconds; triggers a recount during the delay period
- P-15: Give the signal, the relay will stop automatically after pulling in A seconds; trigger the overlay timing during the delay time.
- P-16: Give the signal, the relay will stop automatically after pulling in A seconds; triggers reset during the delay period

P-17: Give the signal, relay suction, input signal disconnection, start timing A seconds later power off, give the signal in the delay period to maintain output again, stop timing.

P-18: After power-on, the relay immediately sucks in, delays A seconds and then cuts off; until the next power-on.

P-21: Give signal, delay A seconds, relay suction

P-22: Give the signal, after more than A seconds, the relay sucks in, the signal disappears and the relay stops.

P-23: After the signal disappears for more than A seconds, the relay closes, the signal disappears and the relay stops.

P-24: When the signal exceeds A seconds, the relay closes and the signal disappears beyond A seconds, the relay stops.

P-25: When the signal exceeds A seconds, the relay sucks in, and when the signal exceeds A seconds again, the relay stops.

P-26: With signal, the relay stops after A seconds, the signal disappears and the relay stops after A seconds again.

P-27: Pulse signal detected, relay stop; no pulse signal, delay A seconds, relay suction; (signal persistence or signal disappearance are considered as no pulse signal)

P-28: After power-on, delay A seconds, relay suction, until power failure

P-31: After power-on, the relay sucks in A seconds, disconnects B seconds, infinite cycle; power off stops

P-32: With signal, start P-31 infinite cycle; signal disappears, stop cycle.

P-33: Give a signal, start P-31 infinite cycle; give another signal to stop cycle

P-34: After power-on, delay A seconds, relay suction, suction B seconds, stop

P-35: Signal, delay A seconds, relay suction, suction B seconds, stop

P-36: There is a signal, after more than A seconds, the relay will suck in, stop after B seconds, the signal disappear, and the time will be cleared and stopped.

P-37: With signal, the relay automatically stops in seconds A and then counts in seconds B after stopping. The signal trigger is invalid in A+B time.

P-38: When the signal is given more than A times, the relay closes in B seconds and stops.

3、 Controller parameter setting

In the single cycle operation mode, the sensor signal triggers the heating operation, and the sensor position can be installed according to the actual situation.

Photoelectric Sensor

Power supply voltage	+5VDC
Control output	NPN NO
Current consumption	100mA
Sensitivity adjustment	One-turn adjuster

3.1 side install

The side mounting is divided into the left side and the right side. As shown in the figure below, both sides have symmetrical mounting holes. The left side is fitted with the processing method of the left side feeding line, and the right side is fitted with the processing method of the right side feeding line.



3.2 Front Installation

The schematic diagram of the front mounting sensor is as follows, which is suitable for the working mode of the front feeding.

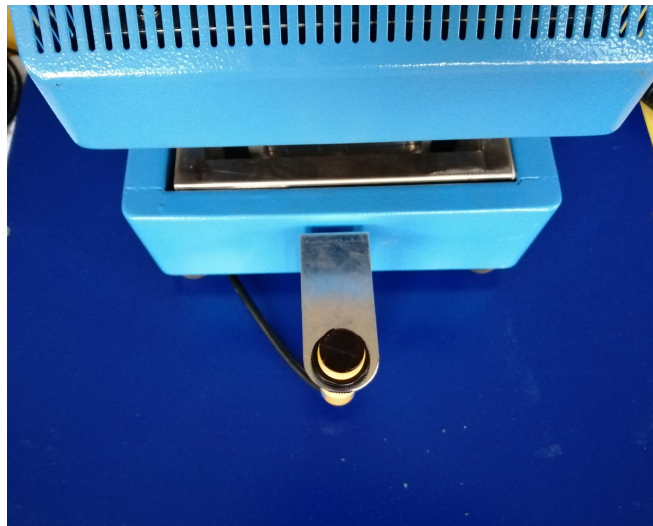

V、equipment running

1、Operation mode

1.1 Single operation mode

Single operation mode refers to the device start-up heating with sensor trigger as the switching signal, after the single mode operation, the secondary start-up needs to trigger the signal again.

for example: P-11 or P-13.

1.2 Circulating operation mode

Cyclic operation mode refers to the alternate cycle operation between heating and stopping heating after the machine starts, until the controller stops the key or disconnects the power supply.

for example: P-31 or P-32 or P-33.

2、 Single run mode operation

Close the circuit breaker and the power indicator will turn on. Adjust the parameters of the controller to signal trigger mode, and set the heating time in seconds. Install the signal trigger sensor, as shown below, or install it on the front. When an object passes over the sensor, the trigger signal starts to heat and the single operation mode starts.

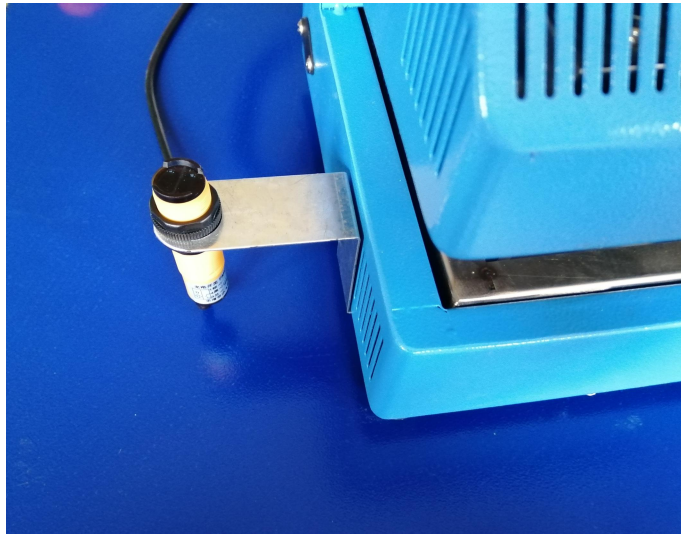

Note: When the trigger object is black, the sensor may not be able to sense it.

3、 Circulating operation mode

Close the circuit breaker and the power indicator will turn on. Adjust the parameters of the controller to the cyclic trigger mode, and set the heating time and stopping time in seconds. The signal trigger could not be installed (according to the cyclic operation mode in practice).

VI、 Common failures and Solutions

Fault	Reason	Processing method
Blower not working	The device is not powered	Connection power
	“Power switch” OFF	Power ON
	Damage of blower	Replacement blower
Heater not working	“Power switch” OFF	Power ON
	Heater damage	Replace heater
	Heater circuit problem	Inspection line
	Heater defect	Replace heater
	Controller damage	Replace Controller

VII、 Equipment adjustment

1. Replacement of heating tube

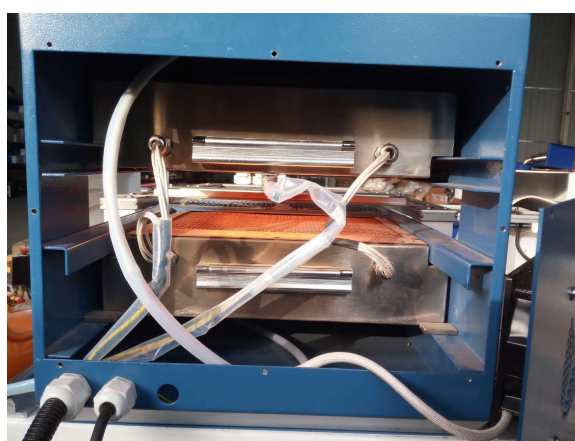
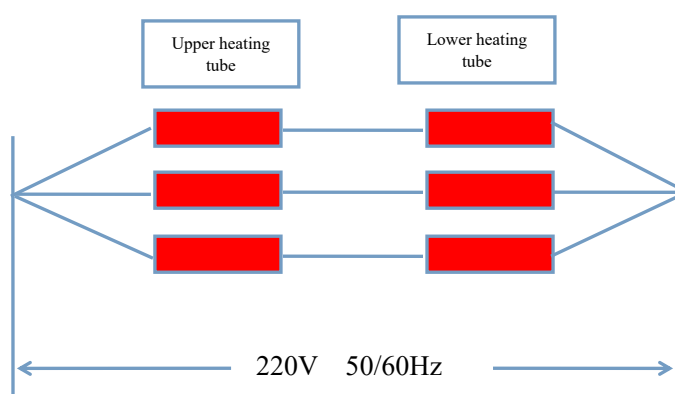

The specification of heating pipe is 110V 300W, so at 220V voltage, the connection mode of heating pipe is two series connection, and the upper and lower correspond to the same position as a group. The wiring is as shown above.

Open the back cover of the heater, as shown in the figure above, remove the

middle baffle, and then extract the heating pipe.

2. Baffle adjustment

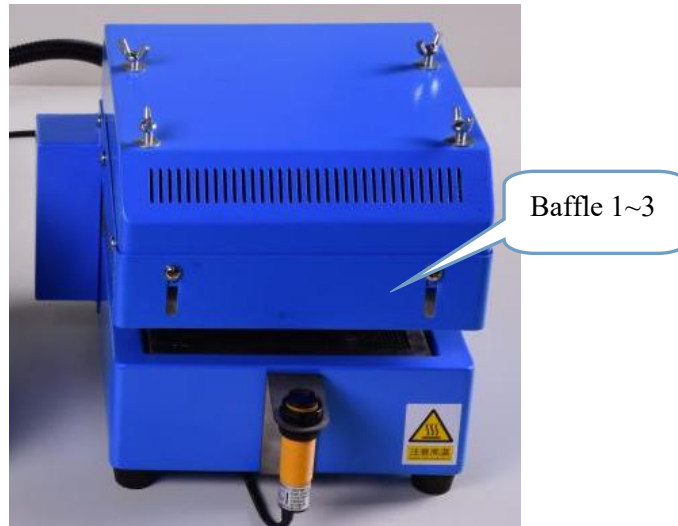

There are three baffles in the left, middle and right positions. The height of the baffle can be adjusted reasonably according to the diameter of the wiring harness to prevent the strong light from illuminating the eyes. If the harness enters from the front, the left and right baffles can be adjusted to the lower limit.

Note: In order to prevent eye damage caused by strong light, wear protective glasses when working.

3. Adjustment of Heating Zone Height

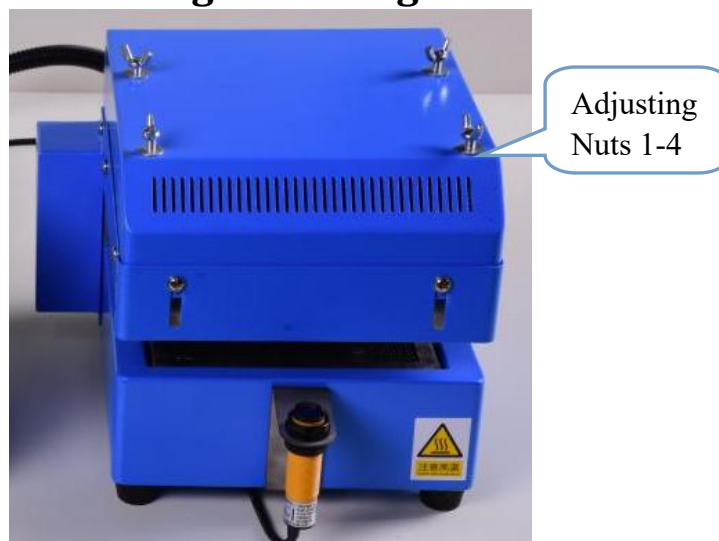

According to the diameter of the wire harness, the height of the upper heating zone can be adjusted to make the upper heating zone in a suitable height range and improve the thermal efficiency. Adjustment method: adjust nuts clockwise in turn,

the upper heating zone is upward, the heating zone height increases, adapting to large diameter wire harness; conversely, the heating zone height decreases, adapting to small diameter wire harness.

VIII、 Regular maintenance

Serial number	Contents of maintenance	Inspection cycle
1	Check whether the rear exhaust fan of heater is running	Every 100 hours of operation
2	Check whether the running current of the equipment is between 7.3A and 7.9A, or whether all the upper and lower heating tubes are heated	Every 100 hours of operation
3	Press the Leakage Circuit Breaker Test Button to check whether the circuit breaker is working properly	Every 100 hours of operation