

Jun.1.2020 Copyright 2020 HIROSE ELECTRIC CO., LTD. All Rights Reserved.
 In case of consideration for using Automotive equipment / device which demand high reliability, kindly contact our sales window correspondents.

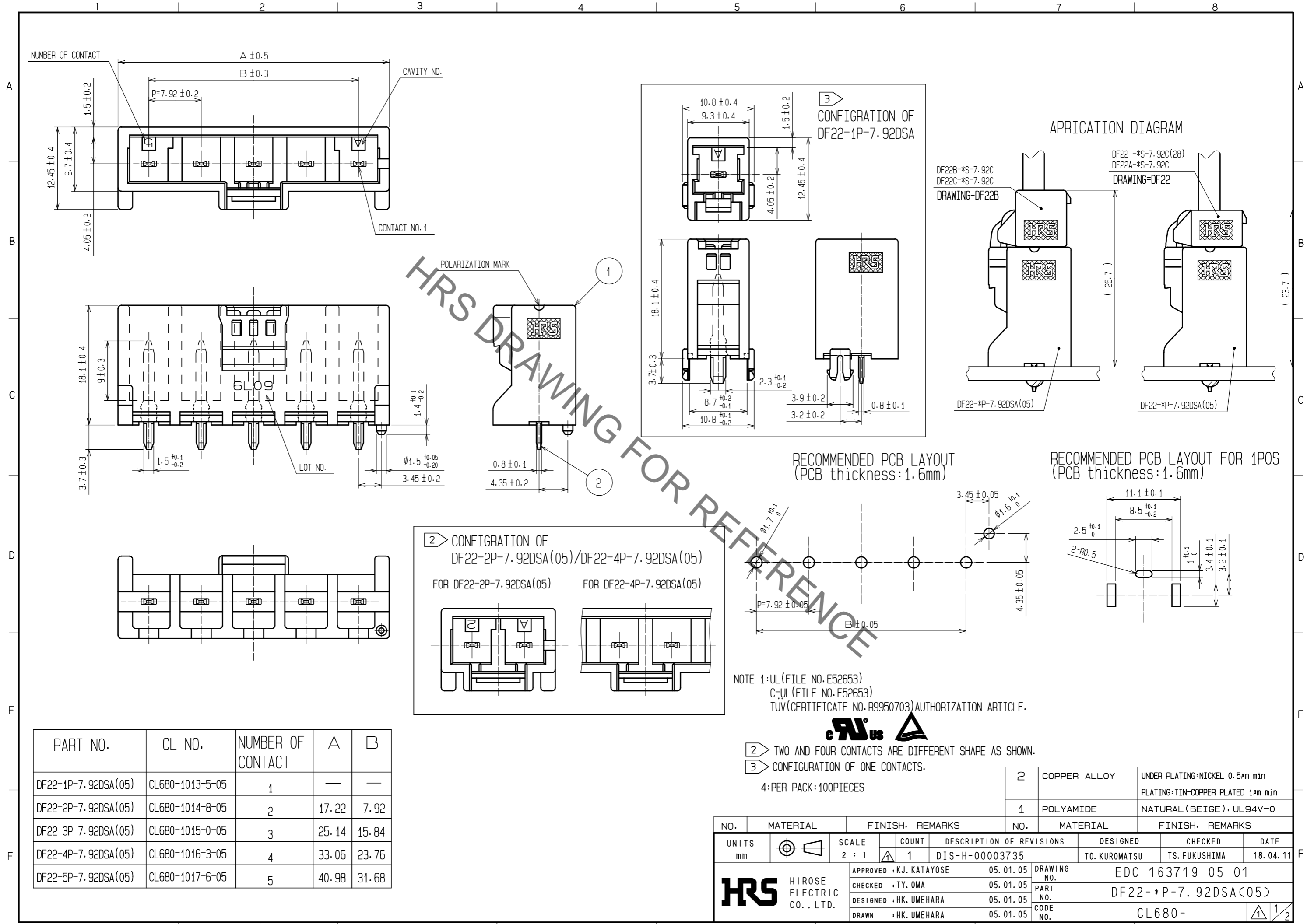

PART NO.	CL NO.	NUMBER OF CONTACT	A	B
DF22-1P-7.92DSA(05)	CL680-1013-5-05	1	—	—
DF22-2P-7.92DSA(05)	CL680-1014-8-05	2	17.22	7.92
DF22-3P-7.92DSA(05)	CL680-1015-0-05	3	25.14	15.84
DF22-4P-7.92DSA(05)	CL680-1016-3-05	4	33.06	23.76
DF22-5P-7.92DSA(05)	CL680-1017-6-05	5	40.98	31.68

NO.	MATERIAL	FINISH, REMARKS	NO.	MATERIAL	FINISH, REMARKS
2	COPPER ALLOY	UNDER PLATING:NICKEL 0.5μm min PLATING:TIN-COPPER PLATED 1μm min	1	POLYAMIDE	NATURAL (BEIGE)・UL94V-0

UNITS	SCALE	COUNT	DESCRIPTION OF REVISIONS	DESIGNED	CHECKED	DATE
mm	2 : 1	1	DIS-H-00003735	TO. KUROMATSU	TS. FUKUSHIMA	18.04.11

APPROVED	DATE	DRAWING NO.
KJ. KATAYOSE	05.01.05	EDC-163719-05-01
TY. OMA	05.01.05	PART NO.
HK. UMEHARA	05.01.05	DF22- * P-7.92DSA(05)
HK. UMEHARA	05.01.05	CODE NO.
		CL680-

Jun.1.2020 Copyright 2020 HIROSE ELECTRIC CO., LTD. All Rights Reserved.
In case of consideration for using Automotive equipment / device which demand high reliability, kindly contact our sales window correspondents.



Precautions

Notification for Insertion Extraction

1) Please insert(extract) the crimping socket straight to the mating connector.
Insertion(extraction) at tilted angles applies load concentration to the connector end and may cause deformation (at connection area, socket and header case, etc). There is firing risk using this kind of deformed connector.

Insertion(Extraction)

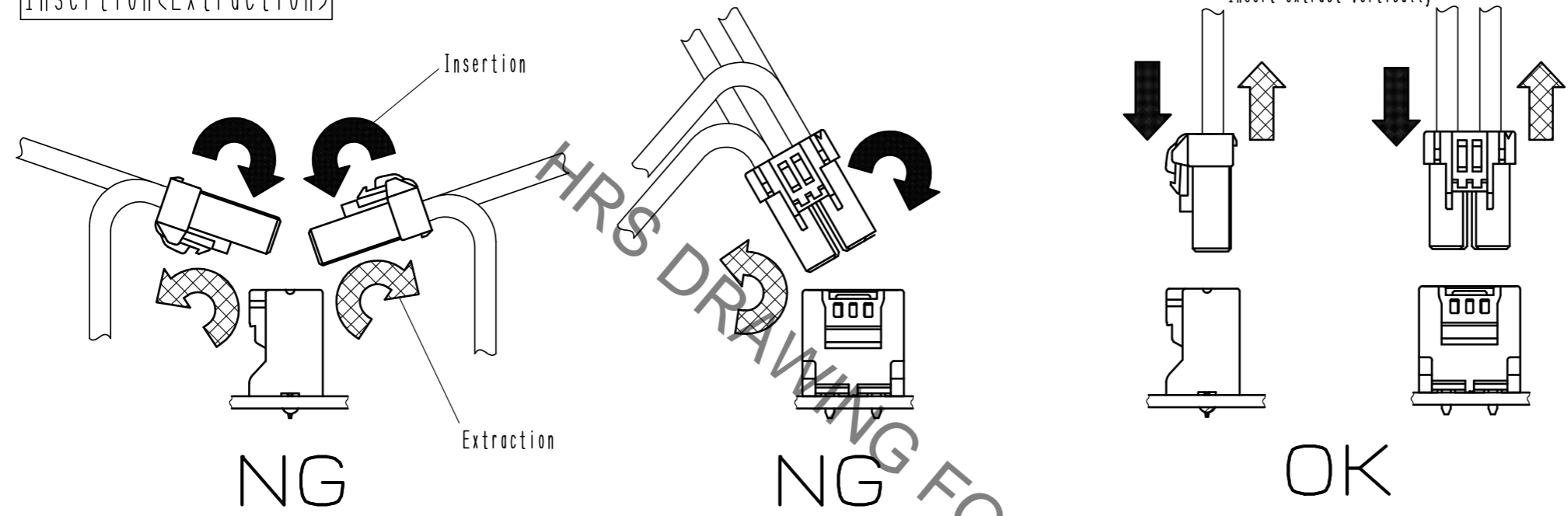

2) When it is hard to extract, please lightly insert the connector beforehand and then pull it with releasing the lock.
Forced extraction has a risk of connector breakage.

Notification of wiring

1) When using a thick cable, short cable length and bending close to the connector end, these load concentration may cause deformation.
Please note that there is firing risk using deformed connector.
When installing, please refrain from stress concentration such as cable bending close to the connector end or cable twisting.

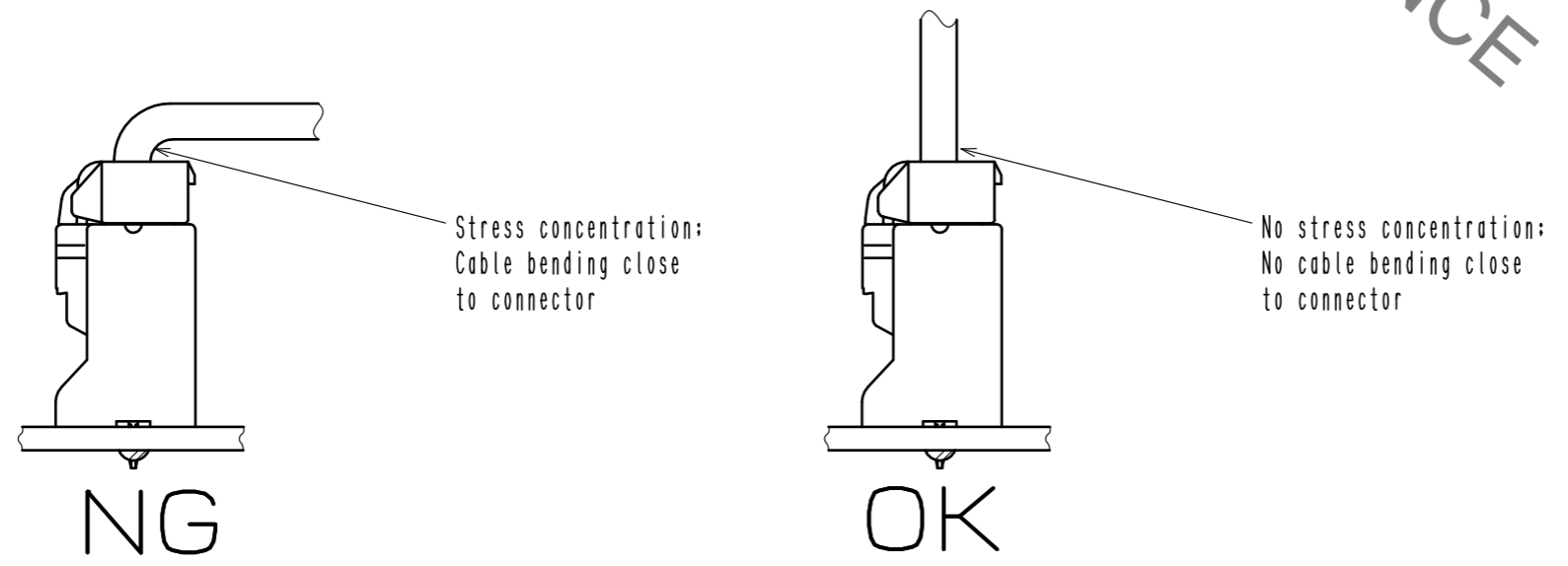

2) When applying load to connector end, please use the retainer for reducing the stress affection on the connector.
Retainer shall be installed after inserted crimping contact completely. It might be impossible to insert it when terminal installation is incompletd.

HRS	DRAWING NO.	EDC-163719-05-01		2/2
	PART NO.	DF22-*P-7.92DSA(05)		
	CODE NO.	CL680-		