

NUMBER C-175152

三角換 (3rd ANGLE PROJECTION)

METRIC

単位: 概 DIMENSIONS IN MM. DO NOT SCALE PRINT

PRINT DIST

AMP-J010-2C
REV. 3/93

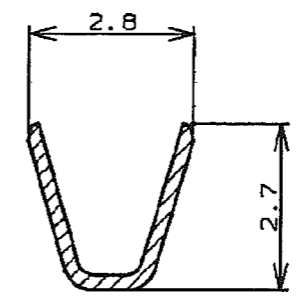
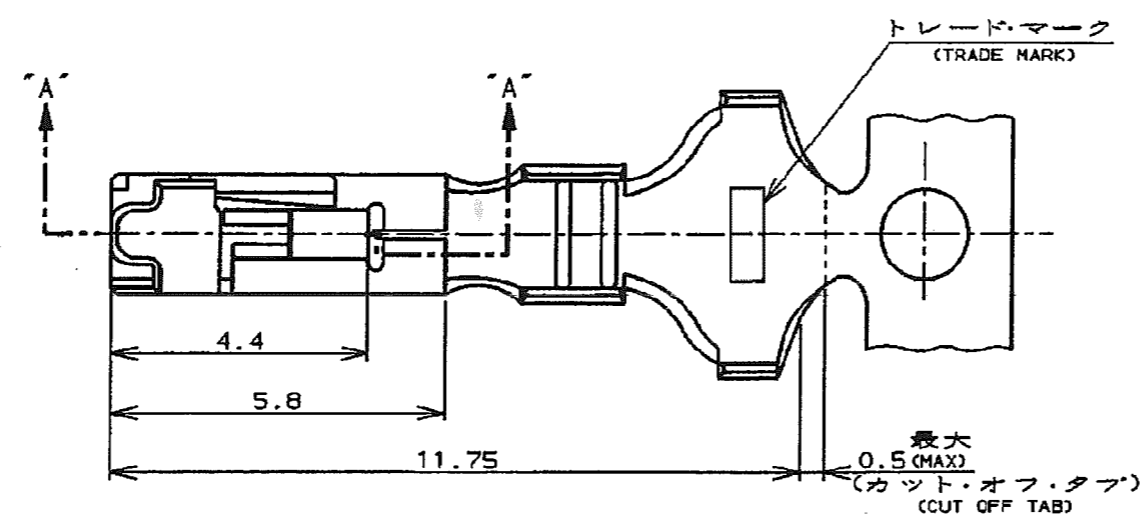

断面 "D"- "D"
(SECT)

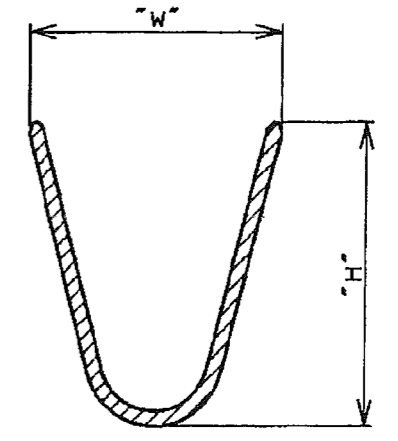

断面 "E"- "E"
(SECT)

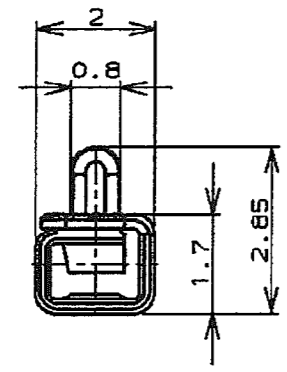

断面 "B"- "B"
(SECT)

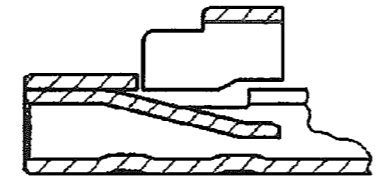
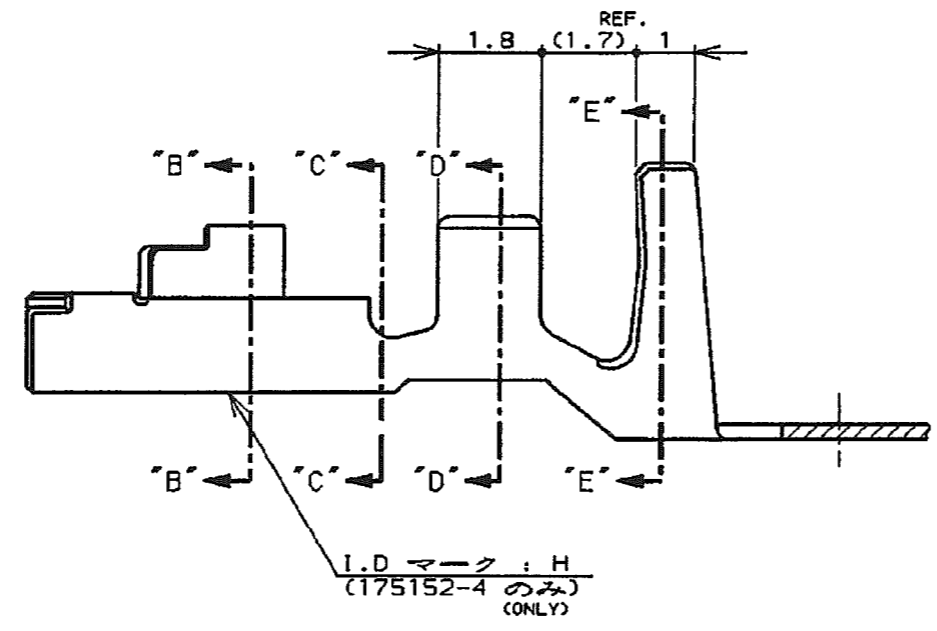

断面 "A"- "A"
(SECT) (175152-1, -2, -3)

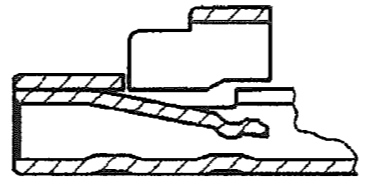

断面 "A"- "A"
(SECT) (175152-4)

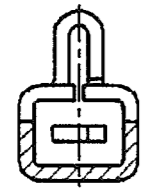

断面 "C"- "C"
(SECT)

注記:

1. 通用規格
製品規格 : 108-5302
取付通用規格 : 114-5142
2. 取扱説明書 : IS-503J
3. 適用ハウジング型番 : 178125

NOTES:

1. APPLICABLE SPEC
PRODUCT SPEC : 108-5302
APPLICATION SPEC : 114-5142
2. INSTRUTION SHEET : IS-503J
3. APPLICABLE HOUSING : 178125

1.7 ~ 3.3	175156-4	4.3	5.2	錫めっき済銅合金 (PRE TINNED COPPER ALLOY)	175152-4
2.9 ~ 4.0	---	4.8	4.7	錫めっき済黄銅 (PRE TINNED BRASS)	△175152-3
1.7 ~ 3.3	175156-2	4.3	5.2	錫めっき済黄銅 (PRE TINNED BRASS)	175152-2
1.7 ~ 3.3	175156-1	4.3	5.2	錫めっき済銅合金 (PRE TINNED COPPER ALLOY)	175152-1
電線被覆外径 (INSULATION DIA)	バラ状端子型番 (L.P.P/N)	"W"	"H"	材料及び仕上 (MATERIAL AND FINISH)	型番 (P/N)
		寸法(DIMENSION)			

				STE TE Connectivity	
相合電線範囲 (WIRE RANGE) 0.50-1.42mm ² (AWG 20-18)		電線外径 (INSULATION DIA.) 表参照 (SEE TABLE) mmφ		名称 (NAME) リセクタクル・コンタクト、アンブ・ユニバーサル・パワー・コネクタ (REC CONTACT AMP UNIVERSAL POWER CONN.)	
材料 (MATERIAL) 表参照 (SEE TABLE)		仕上 (FINISH) 表参照 (SEE TABLE)		一般公差 (GENERAL TOLERANCE) 10mm以下: ±0.2 10mm以上 30mm以下: ±0.25 30mm以上 100mm以下: ±0.3 角 度: ±3°	
F1	REVISED PER ECO-11-005030	RK	HMR	DR. 8. JUN '95 N. NAGASHIMA	DE. 8. JUN '95 M. SHINDO
LTR	変更 (REVISION RECORD)	DR	CHK	CHK. 8. JUN '95 M. SHINDO	APP. 8. JUN '95 Y. KASHIWA
				LOC B J	番号 (No.) C-175152
				尺度 (SCALE)	REV. F1 SHEET 1 OF 1

(CUSTOMER DRAWING) 参考 図 面